

Alternator Models :
KP200IIRS
KP250IIRS
KP270IIRS
KP290IIRS
KP340IIRS
KP370IIRS
 (Ignition-Excite)
 with Remote Sense
 and Battery Isolator

w/Battery Isolator

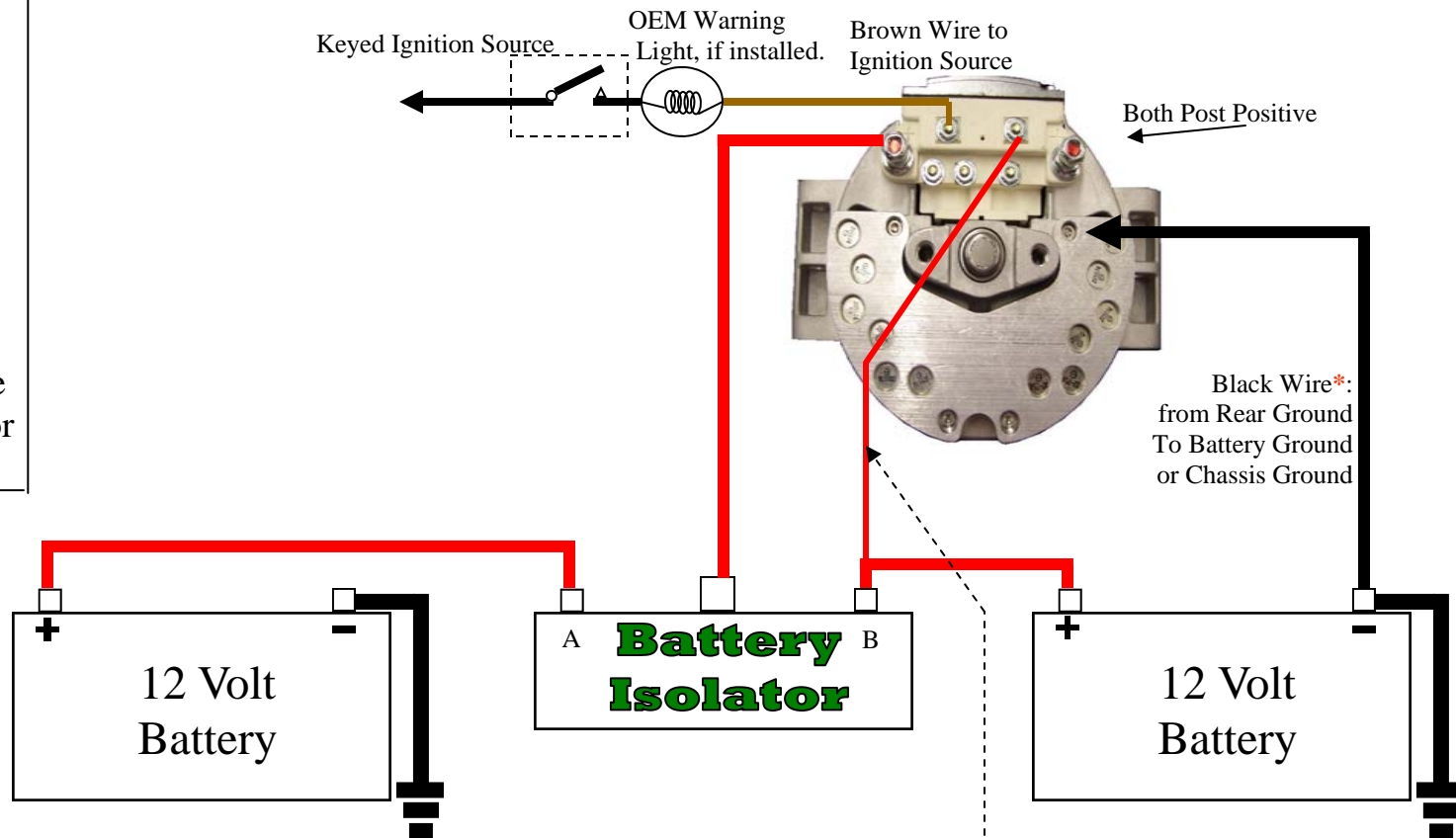

Maximum Amp Load	1 to 10 (Feet)	11 to 15 (Feet)	16 to 20 (Feet)
200 amps	2/0	3/0	4/0
250 amps	3/0	3/0	4/0
300 amps	4/0	4/0	4/0
350 amps	4/0	4/0	N/A
400 amps	4/0	N/A	N/A
450 amps	N/A	N/A	N/A

Remote Sense Wire (Red) must connect either at Battery Positive Post or on output from Isolator that reads within 1/10th of direct battery voltage at all times.

Tech Support
1.318.765.6855
1.318.664.7546
1.214.630.3820

K.E.I. Installation Instructions	
Part # KP Series above	Date: 30 Aug 09
Style: Internally Regulated 12 Volt Alt. Ignition-Excite w/Remote Sense	
Drawn By: DBA	Approved By:

***Note:** Positive and Ground Cables from Alternator and Battery, must be upgraded to at least a minimum size Cable according to chart on this document.